

CONFIGURAZIONE. P1

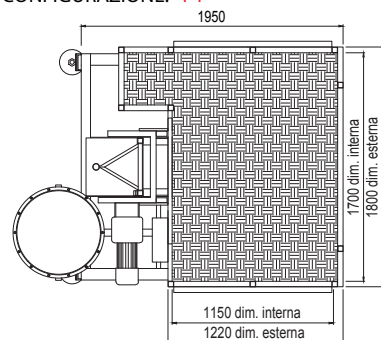

CONFIGURAZIONE. P2

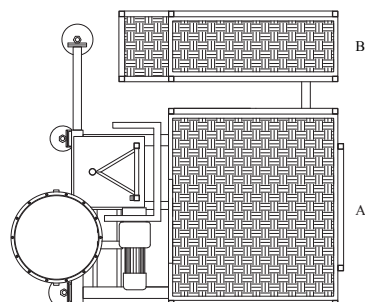
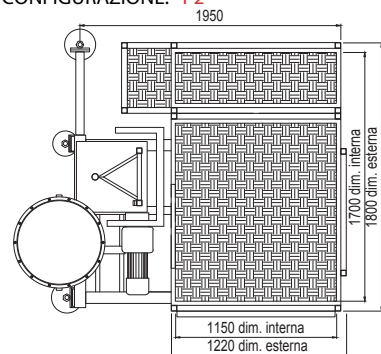

L'elemento A + B compongono la configurazione P2.
L'elemento B può essere utilizzato anche per la sola fase di montaggio e poi rimosso.

CONFIGURAZIONE. P3

CONFIGURAZIONE. P3 (kit opzionale ribaltina di solo montaggio)

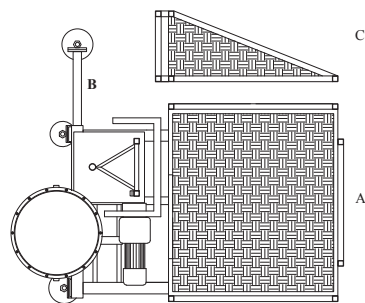
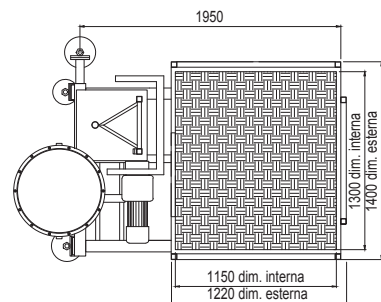

L'elemento C può essere utilizzato per la sola fase di montaggio e poi deve essere rimosso, in questa fase montare sempre il braccio stabilizzante B



RR600 PRO

		VERSIONE MONOFASE CONFIG. P1-P2	VERSIONE MONOFASE CONFIG. P3	VERSIONE TRIFASE CONFIG. P1/P2	VERSIONE TRIFASE CONFIG. P3
DATI TECNICI - RR600 PRO	TECHNICAL DATA - RR600 PRO	SINGLE-PHASE CONFIGURATION VERSION. P1-P2	SINGLE-PHASE CONFIGURATION VERSION. P3	THREE-PHASE CONFIGURATION VERSION. P1/P2	THREE-PHASE CONFIGURATION VERSION. P3
Portata Max kg.(incluso persone)	Maximum capacity kg.(including people).	600	600	600	600
Velocità di spostamento verticale max.	Max. vertical travel speed.	12 mt/min.	12 mt/min.	12 mt/min.	12 mt/min.
Persone Ammesse Max.	People Allowed Max.	5	4	5	4
Dimensione esterna cesta mm.	External cabin size mm.	1800 x 1220	1400 x 1220	1800 x 1220	1400 x 1220
Dimensione ingombro a terra mm.	Floor space dimensions mm.	1800 x 2250	1400 x 2250	1800 x 2250	1400 x 2250
Dimensione per il trasporto mm.	Transport dimension mm.	1800 x 1950	1400 x 1950	1800 x 1950	1400 x 1950
Altezza Max	Max Height.	100 mt.	100 mt.	100 mt.	100 mt.
Intervallo Max tra gli Ancoraggi	Max interval between anchors.	7 mt.	7 mt.	7 mt.	7 mt.
Alimentazione elettrica Trifase	Three-phase electrical power supply.	230V 50/60 Hz	230V 50/60 Hz	400V 50/60 Hz	400V 50/60 Hz
Freni Elettromeccanici	Electromechanical brakes.	1	1	1	1
Freno paracadute	Parachute brake.	1	1	1	1
Potenza Motore	Engine Power.	1 x 2,2 kw	1 x 2,2 kw	1 x 2,2 kw	1 x 2,2 kw
Altezza traliccio trapezoidale mm.	Trapezoidal truss height mm.	1500	1500	1500	1500

TABELLA DI CARICO RR600 PRO PER CONFIG. P1 / P2 - RR600 PRO LOAD TABLE CONFIG. P1 / P2























VERSIONE MONOFASE / SINGLE - PHASE VERSION				VERSIONE TRIFASE / THREE - PHASE VERSION			
Persone / Person	+	Materiali / Materials (kg.)	Tot. kg.	Persone / Person	+	Materiali / Materials (kg.)	Tot. kg.
	1	500 kg.	600 kg.		1	500 kg.	600 kg.
	2	400 kg.	600 kg.		2	400 kg.	600 kg.
	3	300 kg.	600 kg.		3	300 kg.	600 kg.
	4	200 kg.	600 kg.		4	200 kg.	600 kg.
	5	100 kg.	600 kg.		5	100 kg.	600 kg.
Persone / Person max n. 5				Persone / Person max n. 5			
Carico max / Maximum capacity kg. 600				Carico max / Maximum capacity kg. 600			
N.B:  = 100 kg.				N.B:  = 100 kg.			

TABELLA DI CARICO RR600 PRO PER CONFIG. P3 - RR600 PRO LOAD TABLE CONFIG. P3

VERSIONE MONOFASE / SINGLE - PHASE VERSION				VERSIONE TRIFASE / THREE - PHASE VERSION			
Persone / Person	+	Materiali / Materials (kg.)	Tot. kg.	Persone / Person	+	Materiali / Materials (kg.)	Tot. kg.
	1	500 kg.	600 kg.		1	500 kg.	600 kg.
	2	400 kg.	600 kg.		2	400 kg.	600 kg.
	3	300 kg.	600 kg.		3	300 kg.	600 kg.
	4	200 kg.	600 kg.		4	200 kg.	600 kg.
Persone / Person max n. 4				Persone / Person max n. 4			
Carico max / Maximum capacity kg. 600				Carico max / Maximum capacity kg. 600			
N.B:  = 100 kg.				N.B:  = 100 kg.			