

piattaforma aerea Ragno 39 metri con verricello





BI-ENERGY

 Diesel
18,2 kW

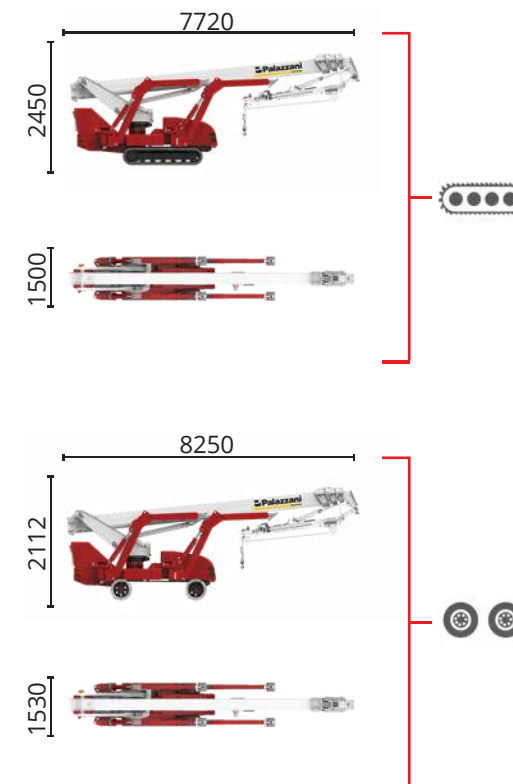
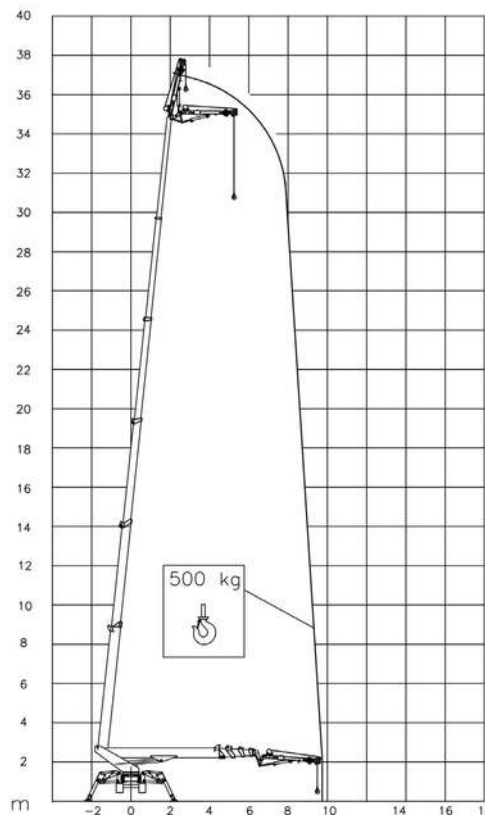
 Single-phase
Electric motor
230VAC - 2,2 kW



TSJ 39/C		37 m	9,7 m	500 kg	660°	240x70 cm	90°+80°	2,92-4,7 m	18%	40%	1,8 km/h	7960 kg	47 kN	3,41 kN/m ²	4,3 kN/m ²
TSJ 39/R		37 m	9,7 m	500 kg	660°	240x70 cm	90°+80°	2,92-4,7 m	31%	12%	1,4 km/h	7800 kg	47 kN	3,35 kN/m ²	3,94 kN/m ²

Available power options:



BI-ENERGY (DIESEL+AC)

ECO (AC+BATTERY)

HYBRID (DIESEL+AC+BATTERY)

NC 813 A 22

Characteristics and technical data are informative only and subjected to change without notice.



HOIST

VENDITA E NOLEGGIO DI SISTEMI AD ALTA QUOTA

+39 335 8355930

081 18962737

piattaformaereehoist.it

piattaforma aerea Ragno 39 metri con verricello



ECO

Single-phase
Electric motor
230VAC - 16 kW

Lithium iron
phosphate battery
LiFePO4
48V - 315 Ah

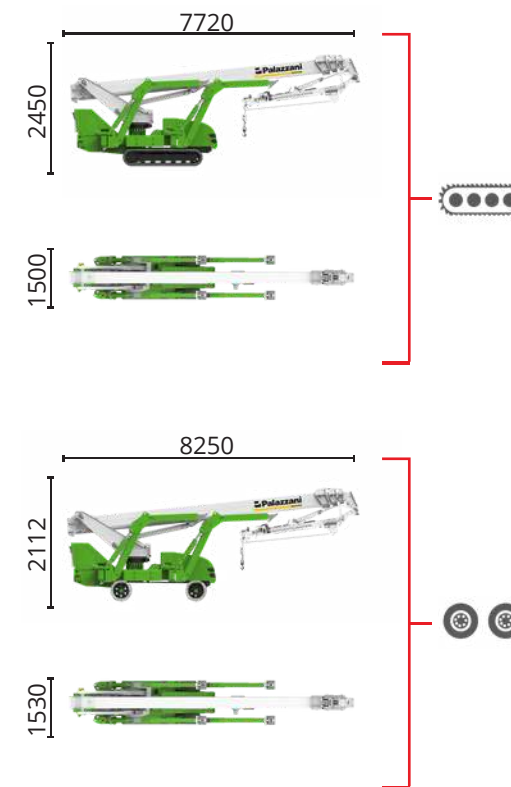
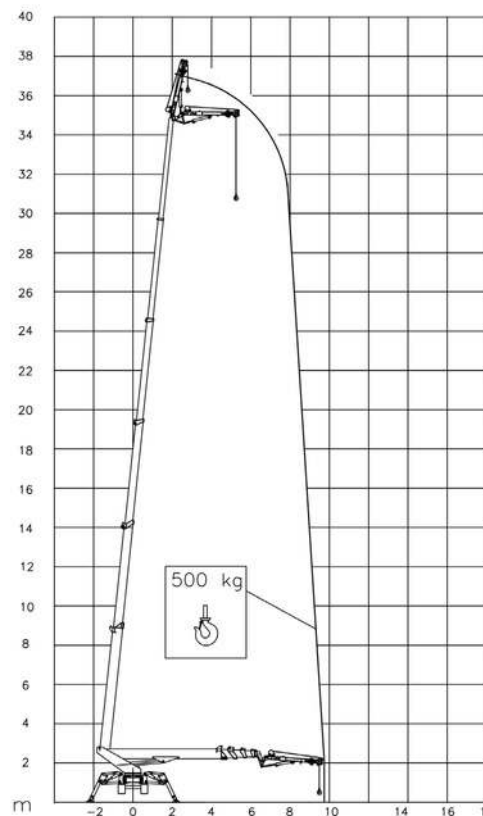

TSJ 39/C		37 m	9,7 m	500 kg	660°	240x70 cm	90°+80°	2,92-4,7 m	18%	40%	1,8 km/h	7960 kg	47 kN	3,41 kN/m ²	4,3 kN/m ²
TSJ 39/R		37 m	9,7 m	500 kg	660°	240x70 cm	90°+80°	2,92-4,7 m	31%	12%	1,4 km/h	7800 kg	47 kN	3,35 kN/m ²	3,94 kN/m ²

Available power options:

BI-ENERGY (DIESEL+AC)

ECO (AC+BATTERY)

HYBRID (DIESEL+AC+BATTERY)



NC 815 A 22

Characteristics and technical data are informative only and subjected to change without notice.



+39 335 8355930

081 18962737

piattaformeareehoist.it

piattaforma aerea Ragno 39 metri con verricello



HYBRID²

- Diesel
14,7 kW
- Single-phase
Electric motor
230VAC - 16 kW
- Lithium iron
phosphate battery
LiFePO4
48V - 315 Ah

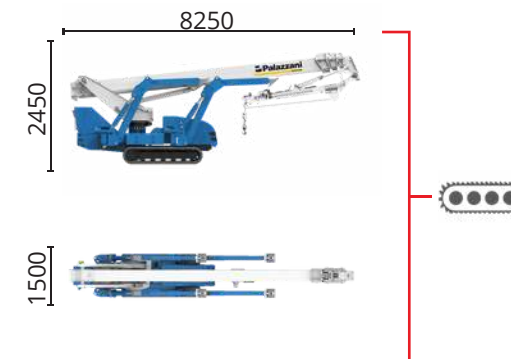
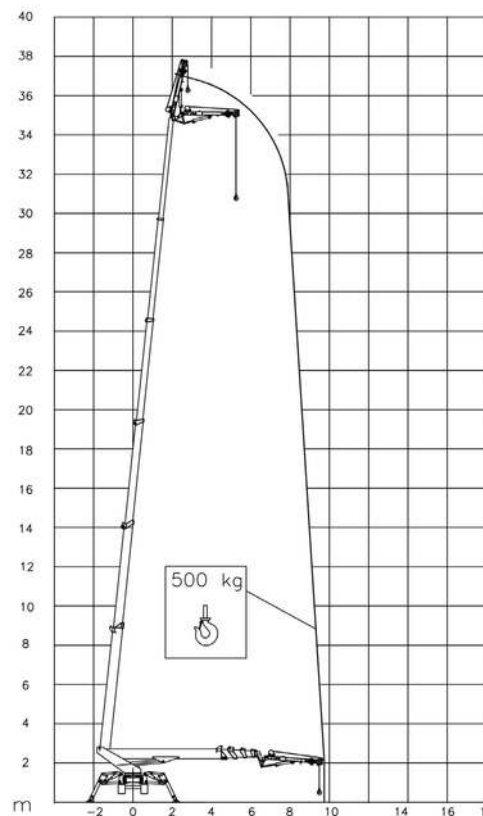

TSJ 39/C 37 m 9,7 m 500 kg 660° 240x70 cm 90°+80° 2,92-4,7 m 18% 40% 2,2 km/h 8100 kg 47 kN 3,47 kN/m2, 0,9 kN/m2

Available power options:

BI-ENERGY (DIESEL+AC)

ECO (AC+BATTERY)

HYBRID² (DIESEL+AC+BATTERY)



NC 817 A 22

Characteristics and technical data are informative only and subjected to change without notice.



+39 335 8355930

081 18962737

piattaformeareehoist.it